

Product catalog

Häggglunds CA

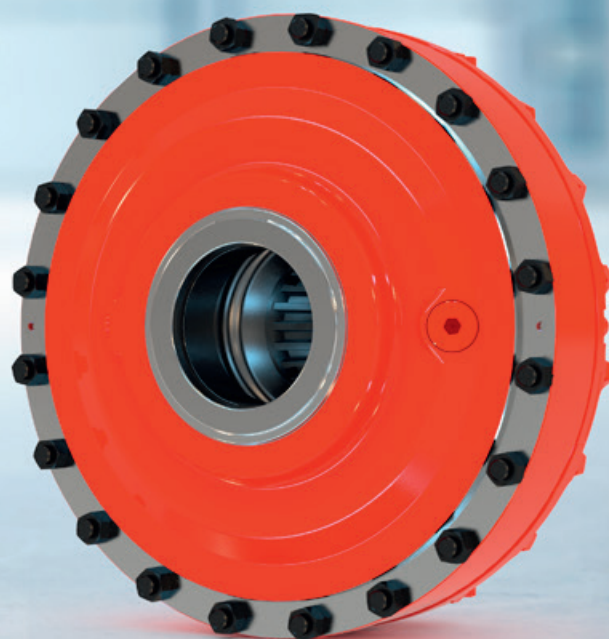

The drive behind your success

A Hägglunds hydraulic direct drive is a drive system beyond the ordinary. In far less space than other drives – and with far less weight and complexity – it delivers flexible, reliable power.

With a Hägglunds drive, your machine has unlimited access to high torque. Yet it's also protected from torque stresses. You get the power and stamina to do more, but with less strain, less wear and less maintenance hassle. Put simply, you get a drive that goes the distance. And behind it is a company that goes the distance with you.

Benefits of a hydraulic direct drive

- ▶ Robust design without gearbox or couplings
- ▶ Compact installation with the motor on the driven shaft
- ▶ Full torque throughout the speed range – without over-sizing
- ▶ High starting torque that can be sustained indefinitely
- ▶ Infinite variations within the speed range
- ▶ Smooth acceleration and deceleration
- ▶ Unlimited starts and stops without overheating
- ▶ Nearly instantaneous emergency stops
- ▶ Built-in protection against shock loads
- ▶ Perfect load sharing between multiple motors

THE JOURNEY

A Hägglunds solution is a total solution – of which the drive system itself is only one part. It's a complete answer to your needs, built as much on knowledge, experience and commitment as it is on drive technology.

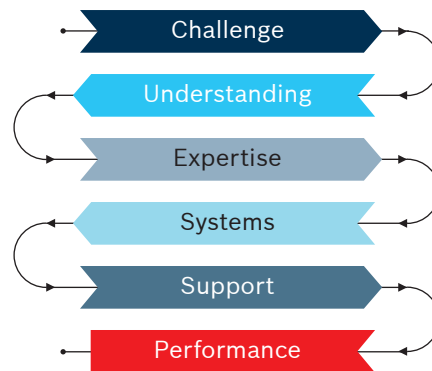

POWERFUL SIMPLICITY

A Hägglunds direct drive system comprises a hydraulic motor and a flexibly placed drive unit, overseen by a control and monitoring system. This simple configuration withstands the challenges of virtually any application or environment.

Mounted directly on the driven shaft, the compact motor supplies reliable power. The force and direction of the

motor's rotation is determined by the fast-acting hydraulic pumps in the drive unit, while the control and monitoring system provides information and advanced functionality. Supporting these components is a wide range of valves and accessories, creating even greater flexibility in installation and operation.



▲ **From the bitter cold of Siberia to the blistering heat of Africa, Hägglunds direct drive systems withstand the challenges of any environment and any type of industry. The drive units can be supplied in a wide range of power levels and configurations, and are function-tested before delivery.**

Power in a compact solution

The Hägglunds CA motor was developed for a very specific purpose: to provide a tough and powerful solution for heavyduty applications where size and weight are significant issues. The result is a really compact hydraulic drive with the same durability, excellent performance and reliability as other Hägglunds motors from Bosch Rexroth. With its small envelope size and light-weight, the Hägglunds CA has an excellent power to weight ratio. Popular features of the Hägglunds CA motor are for example the numerous mounting options, the very useful through hole and the insensitivity to shock loads. When matched to your needs Hägglunds CA provides real competitive advantages in your plant operations. The benefits of using a Hägglunds CA motor are many.

Features

- ▶ High power density
- ▶ High torque density
- ▶ Energy efficient
- ▶ Flexible, many sizes, few mechanical interfaces.
- ▶ Insensitive for shock loads
- ▶ Very low moment of inertia
- ▶ Small footprint (total occupied volume)
- ▶ Freewheeling possibility
- ▶ Through hole option available

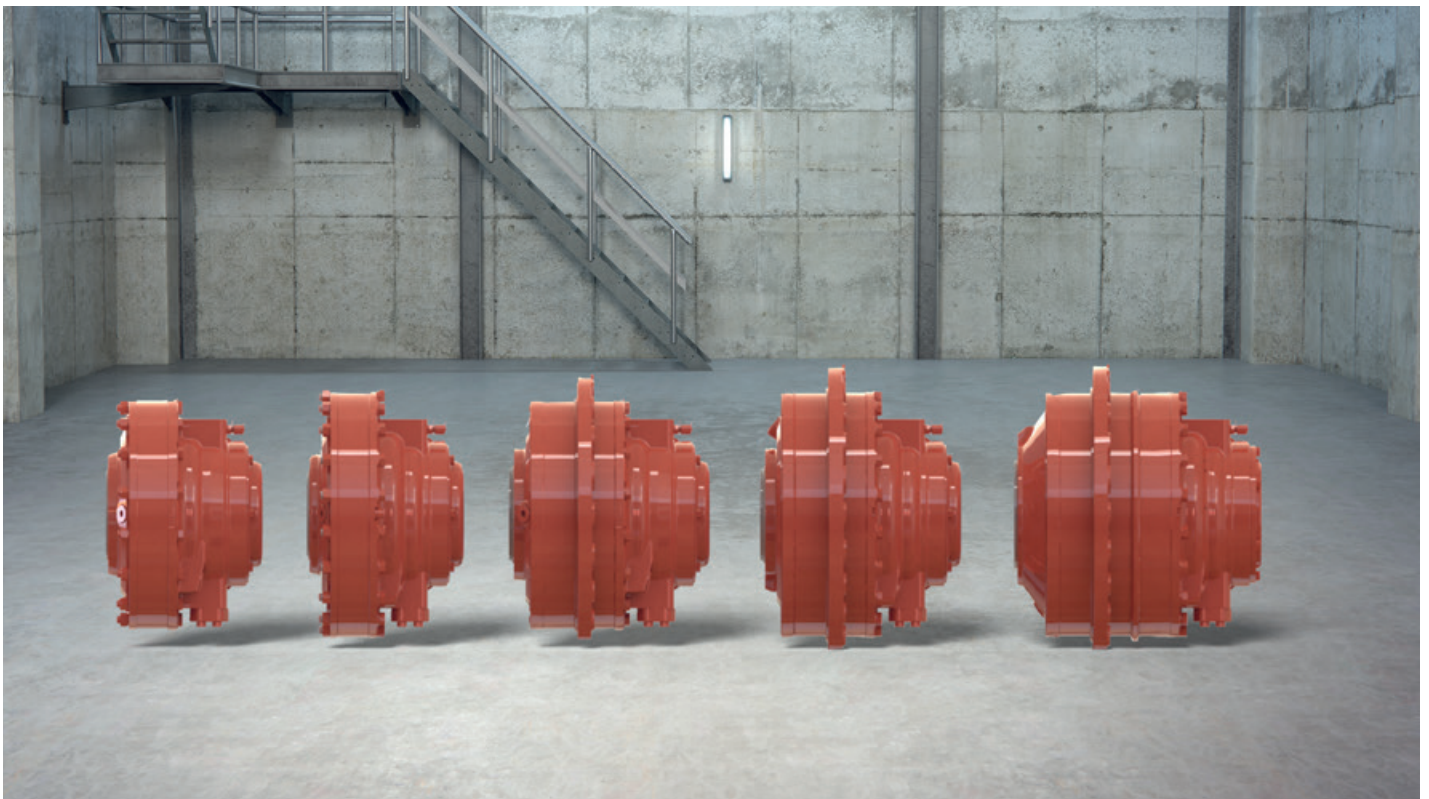

Häggglunds CA in short

Bosch Rexroth's hydraulic industrial motor Häggglunds CA is of the radial piston type with a rotating cylinder block/hollow shaft and a stationary housing. The cylinder block is mounted in fixed roller bearings in the housing. An even number of pistons are radially located in bores inside the cylinder block, and the distributor directs the incoming and outgoing oil to and from the working pistons. Each piston is working against a cam roller.

When the hydraulic pressure is acting on the pistons, the cam rollers are pushed against the slope on the cam ring that is rigidly connected to the housing, thereby producing a torque. The cam rollers transfer the reaction force to the pistons which are guided in the cylinder block. Rotation therefore occurs, and the torque available is proportional to the pressure in the system.

Oil main lines are connected to ports A and C in the connection housing and drain lines to one of the D -ports in the motor housing.

The motor is connected to the shaft of the driven machine through the hollow shaft or spline of the cylinder block.

The symmetrical design of the motor has made it possible to design it as a dual displacement motor. This means that two different displacements and speeds can be obtained for a given flow. To get the 2-speed function, a motor prepared for two speeds has to be ordered together with a 2-speed valve.

Quality

To assure our quality we maintain a Quality Assurance System, certified to standard ISO 9001.

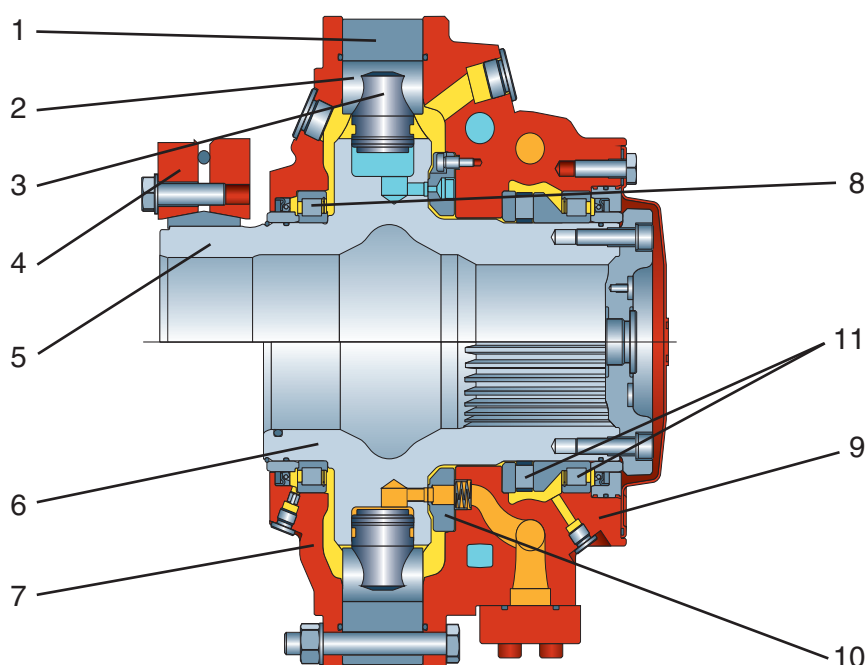

1. Cam ring
2. Cam roller
3. Piston
4. Shrink disc
5. Cylinder block / hollow shaft
6. Cylinder block / spline
7. Housing cover
8. Cylindrical roller bearing
9. Connection housing
10. Distributor
11. Combined axial and radial bearing

Ordering code

In order to identify Hägglunds equipment exactly, the following ordering code is used. These ordering codes should be stated in full in all correspondence e.g. when ordering spare parts.

Example Hägglunds CA motor:

CA		50		50		S	A	0	N	0	C		00		00
01		03		04		05	06	07	08	09	10		11*		12*

01	Motor series	
	Compact CA	CA

03	Frame size	
	CA 50	50
	CA 70	70
	CA 100	100
	CA 140	140
	CA 210	210

04	Nominal size , specific torque, Nm/bar					
	Frame size 50	20	25	32	40	50
		•	•	•	•	•
	Frame size 70		40	50	60	70
			•	•	•	•
	Frame size 100	40	50	64	80	100
		•	•	•	•	•
	Frame size 140		80	100	120	140
			•	•	•	•
	Frame size 210			160	180	210
				•	•	•

05	Mounting alternatives, shaft	
	Splines	S
	Shrink disk coupling	C

06	Motor prepared for tandem kit	
	Motor without brake or tandem kit	A
	Motor prepared for brake or Tandem	B

07	Displacement shift		
	Single speed motor		0
	Two speed motor, rotation clockwise (As viewed from shaft end and inlet to A port)		R
	Two speed motor, rotation counter clockwise (As viewed from shaft end and inlet to A port)		L
08	Type of seal		
	NBR (Nitrile)	●	N
	FPM (Viton)	●	V
09	Through hole kit		
	No	●	0
	Yes	●	H
10	Increased robustness		
	No	●	0
	Yes	●	C
11	Modification		
			00-99
12	Design		
	Standard		00
	Special index		01-99

● = Available – Not available

Configuration options

Hägglunds CA has a variety of standard configurations available, as shown in the order code. Below is an introduction to the possible alternatives and for further information, see data sheet RE15305.

MOUNTING ALTERNATIVES, SHAFT

The Hägglunds CA motors are available with spline hollow shaft or shrink disc coupling.

MOTOR PREPARED FOR TANDEM KIT OR BRAKE

It is possible to mount a brake on the back of the motor. For more information regarding available brake types, see data sheet RE15305.

This configuration is also required if the motor is a front motor in a tandem combination. The motor is then mounted with the back motor and a tandem kit.

DISPLACEMENT SHIFT

The Hägglunds CA can be configured with displacement shift and used together with a Hägglunds VTCA 600 valve. The motor will then have a 2-speed function where the hydraulic connections of the motor are adapted to the rotational direction of the motor. The main rotational direction of the motor during half-displacement must be specified in the order code.

TYPE OF SEAL

The standard seal, NBR (Nitrile) is the preferred alternative in applications with moderate ambient temperatures and moderate case oil temperatures.

The FPM (Viton) seal is the preferred alternative at higher case oil temperatures and at speed above 280 rpm. Viton seal is also preferred for certain hydraulic fluids, for more details, see RE15414 (Hydraulic fluid quick reference).

THROUGH HOLE KIT

The through hole kit enables a through hole of 110 mm in diameter through the motor and e.g. enables flushing of the driven machine or the possibility to draw cables through the motor to the machine.

INCREASED ROBUSTNESS

Hägglunds CA can be configured with standard (uncoated) or coated pistons assembly. Coated pistons and rollers are required if operating at speed <5 rpm or if operating parameters (eg. viscosity) are unclear.

MODIFICATION

The modification represent the design change and is not applicable for configuration.

DESIGN

In addition to the standard design motors, there are also so called special index motors available. For available versions of special index motors, see data sheet RE15305



Motor data

Metric motor data

Motor type	Full displacement			Max. pressure**	Displacement shift			Ratio
	Displacement	Specific torque	Max. speed*		Displacement	Specific torque	Max. speed	
	cm ³ /rev	Nm/bar	rev/min		bar	cm ³ /rev	Nm/bar	
CA 50 20	1 256	20	400	350				
CA 50 25	1 570	25	400	350				
CA 50 32	2 010	32	400	350				
CA 50 40	2 512	40	350	350				
CA 50	3 140	50	280	350	1 570	25	280	1:2
CA 70 40	2 512	40	400	350				
CA 70 50	3 140	50	320	350	1 570	25	320	1:2
CA 70 60	3 771	60	275	350	1 886	30	275	1:2
CA 70	4 400	70	240	350	2 200	35	240	1:2
CA 100 40	2 512	40	400	350				
CA 100 50	3 140	50	400	350				
CA 100 64	4 020	64	390	350				
CA 100 80	5 024	80	310	350	2 512	40	310	1:2
CA 100	6 280	100	270	350	3 140	50	270	1:2
CA 140 80	5 024	80	340	350				
CA 140 100	6 280	100	275	350	3 140	50	275	1:2
CA 140 120	7 543	120	245	350	3 771	60	245	1:2
CA 140	8 800	140	220	350	4 400	70	220	1:2
CA 210 160	10 051	160	150	350	5 026	80	150	1:2
CA 210 180	11 314	180	135	350	5 657	90	135	1:2
CA 210	13 200	210	115	350	6 600	105	115	1:2

**Not recommended to be used
in reduced displacement**

* Speed above 280 rpm requires viton seals. Max permitted continuous case pressure is 2 bar/29 psi.

** The motors are designed according to DNV-rules. Test pressure 420 bar/6000 psi. Peak/transient pressure 420 bar/6000 psi maximum, allowed to occur 10000 times.

US motor data

Motor type	Full displacement			Max. pressure**	Displacement shift			Ratio
	Displacement	Specific torque	Max. speed*		Displacement	Specific torque	Max. speed	
	in ³ /rev	lbf-ft/1 000psi	rev/min		psi	in ³ /rev	lbf-ft/1 000psi	
CA 50 20	76.6	1 017	400	5 000				
CA 50 25	95.8	1 271	400	5 000				
CA 50 32	122.6	1 627	400	5 000				
CA 50 40	153.3	2 034	350	5 000				
CA 50	191.6	2 543	280	5 000	95.8	1 271	280	1:2
CA 70 40	153.3	2 034	400	5 000				
CA 70 50	191.6	2 543	320	5 000	95.8	1 271	320	1:2
CA 70 60	230.1	3 051	275	5 000	115.1	1 526	275	1:2
CA 70	268.5	3 560	240	5 000	134.3	1 780	240	1:2
CA 100 40	153.3	2 034	400	5 000				
CA 100 50	191.6	2 543	400	5 000				
CA 100 64	245.3	3 254	390	5 000				
CA 100 80	306.6	4 068	310	5 000	153.3	2 034	310	1:2
CA 100	383.2	5 085	270	5 000	191.6	2 543	270	1:2
CA 140 80	306.6	4 068	340	5 000				
CA 140 100	383.2	5 085	275	5 000	191.6	2 543	275	1:2
CA 140 120	460.3	6 102	245	5 000	230.1	3 050	245	1:2
CA 140	537	7 119	220	5 000	268.5	3 560	220	1:2
CA 210 160	613.2	8 136	150	5 000	306.7	4 068	150	1:2
CA 210 180	690.4	9 154	135	5 000	345.2	4 577	135	1:2
CA 210	805.5	10 678	115	5 000	402.8	5 339	115	1:2

* Speed above 280 rpm requires viton seals. Max permitted continuous case pressure is 2 bar/29 psi.

** The motors are designed according to DNV-rules. Test pressure 420 bar/6 000 psi. Peak/transient pressure 420 bar/6 000 psi maximum, allowed to occur 10 000 times.

Dimensions

HÄGGLUNDS CA MOTORS WITH SPLINES FOR TORQUE ARM MOUNTING

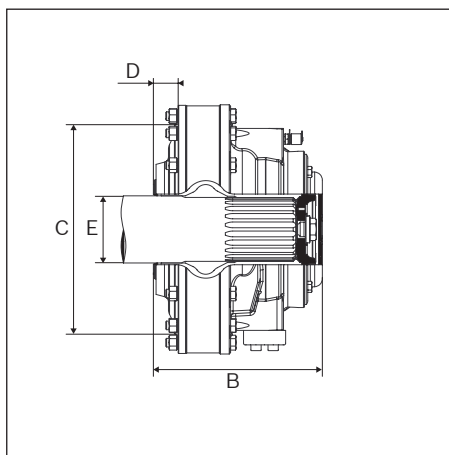
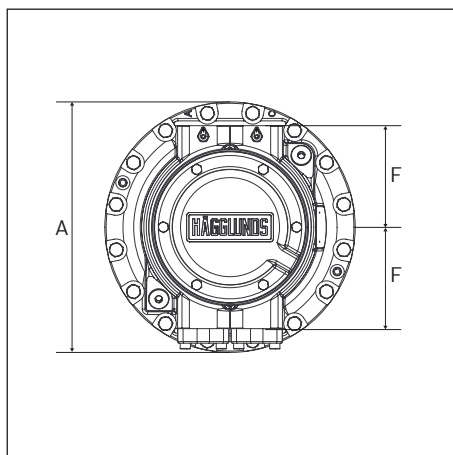

▲ Hägglunds CA 50, CA 70

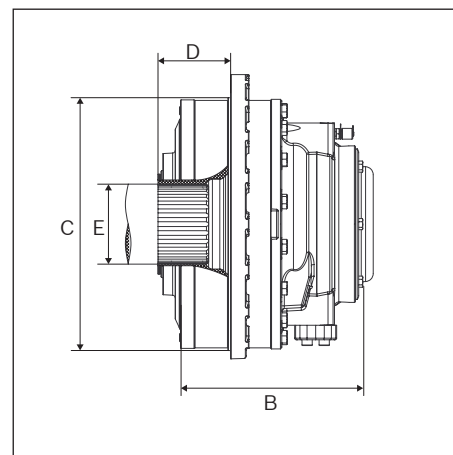

▲ Hägglunds CA 100, CA 140, CA 210

	CA 50	CA 70	CA 100	CA 140	CA210
A mm	464	495	560	600	
B mm	312.5		399.5		501
C mm	390	435	470	510	
D mm	46.5		135.5	135	156.5
E	N120x5x30x22x9H		N140x5x30x26x9H		N150x5x30x28x9H
F mm	188				
Weight kg	175	205	265	305	395
Main conn.	SAE 1 1/4"				
Drain conn.	BSP 3/4"				

Note: For more detailed information about dimensions, see data sheet Hägglunds CA (RE15305)

HÄGGLUNDS MOTOR WITH HOLLOW SHAFT, SHRINK DISC COUPLING

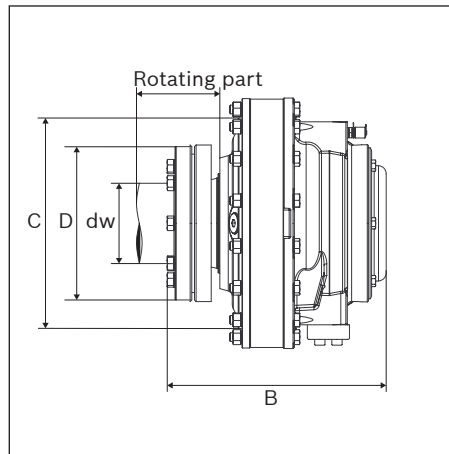
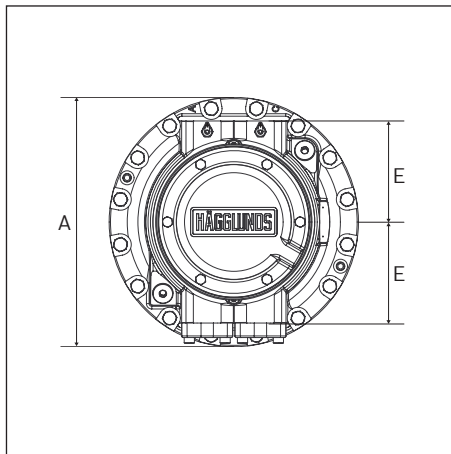

▲ Hägglunds CA 50, CA 70

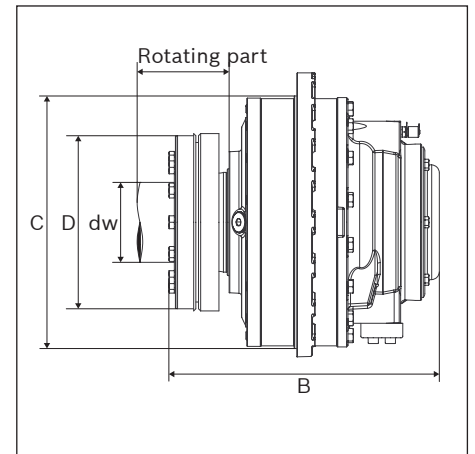

▲ Hägglunds CA 100, CA 140, CA 210

	CA 50	CA 70	CA 100	CA 140	CA210
A mm	464	495	560	600	
B mm	404.4		505	644.5	
C mm	390	435	470	510	
D mm	290		330	350	
E mm	188				
dw mm	120		140	160	
Weight kg	203	232	310	347	456
Main conn.	SAE 1 1/4"				
Drain conn.	BSP 3/4"				

Note: For more detailed information about dimensions, see data sheet Hägglunds CA (RE15305)

Installation examples

The tough radial piston hydraulic motors are weight and space saving and offers versatile mounting possibilities

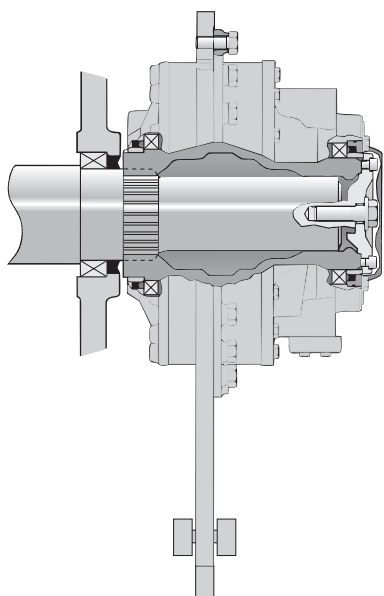

▲ Torque arm mounted motor with splines.

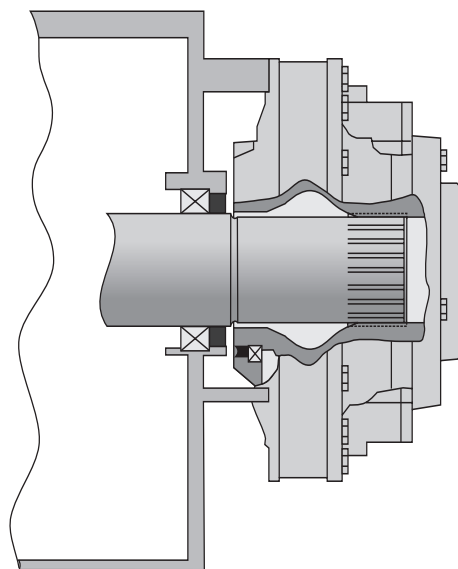

▲ Flange mounted motor with splines

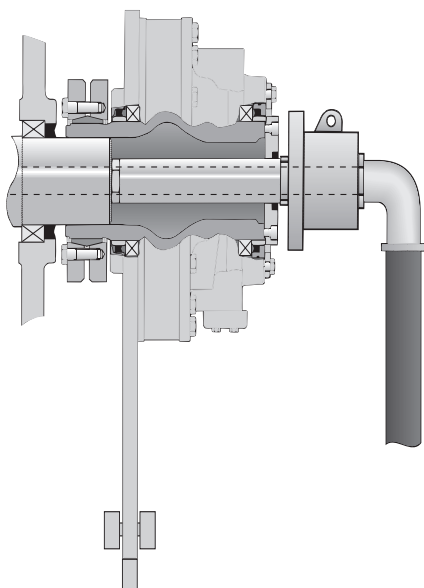

▲ Torque arm mounted motor with shrink disc coupling and through hole for cooling of driven machine

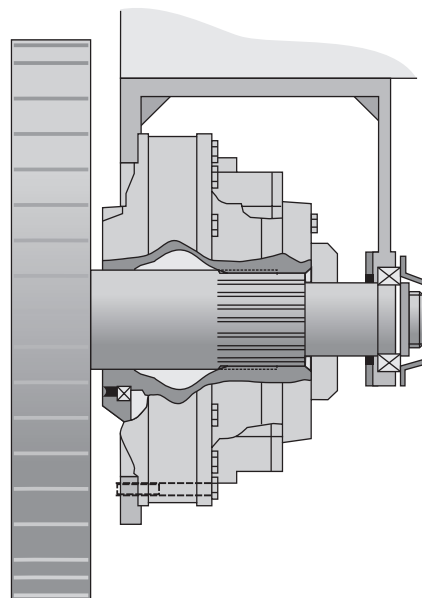

▲ Flange mounted motor with through shaft for high radial load

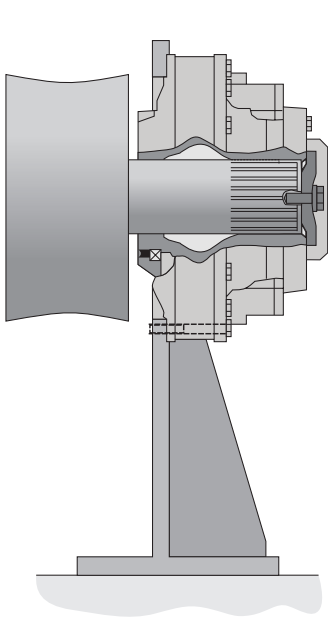

▲ Bracket mounted capstan drive.

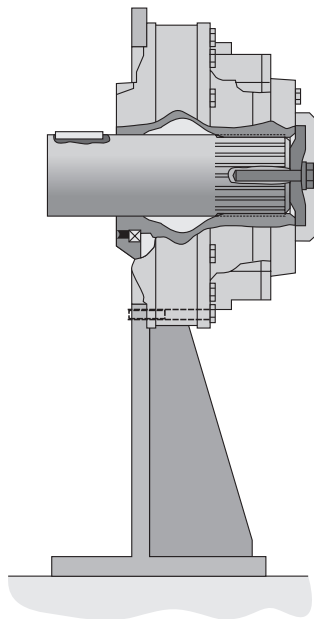

▲ Bracket mounted motor with stub shaft.

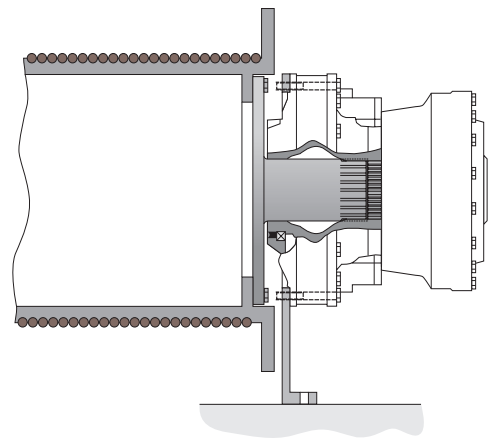

▲ Direct mounted winch drum drive with brake.

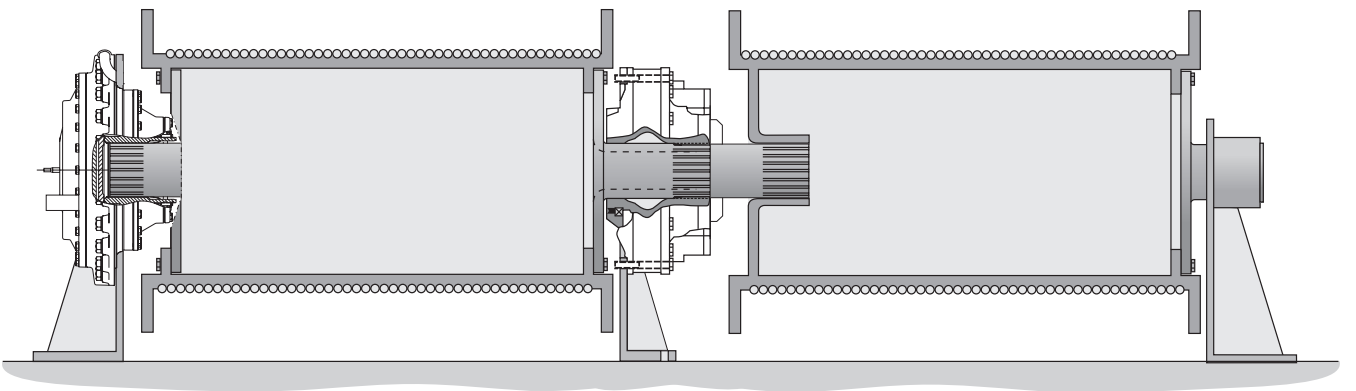

▲ Direct mounted double winch drum drive with brake.

Application examples



▲ Long travel drive



▲ Winch



▲ Shredder



▲ Shredder/feed optimizer roll



▲ Drilling /top drive

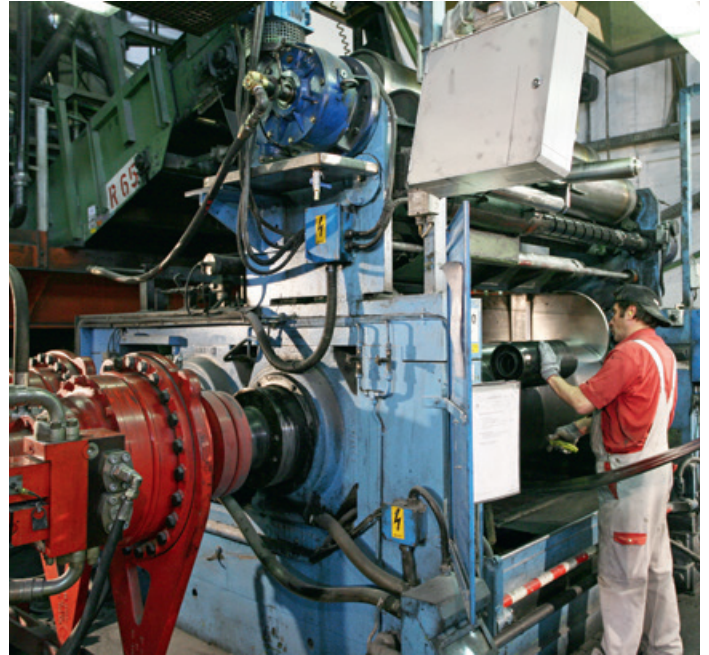

▲ Roll mill



▲ Belt conveyor



▲ Shredder

Accessories

A compact and efficient design can be achieved by means of our standard Hägglunds accessories program.

TORQUE ARMS

Features:

- ▶ Easy mounting - no alignment problems
- ▶ Space saving - close mounting of motor to the driven machine
- ▶ Reduction of external force on driven shaft with double ended torque arm type DTC.

Single ended torque arms Hägglunds TC A

A shaft mounted gearless drive is achieved by utilizing the standard Hägglunds torque arm. Spline shaft for external load, or shaft for shaft coupling can be used.

Double ended torque arms Hägglunds DTCA

If the driven machine or the driven shaft can not stand the forces generated by a single ended torque arm arrangement. In such a case a double ended torque arm is the solution.

For more information see datasheet RE15355.

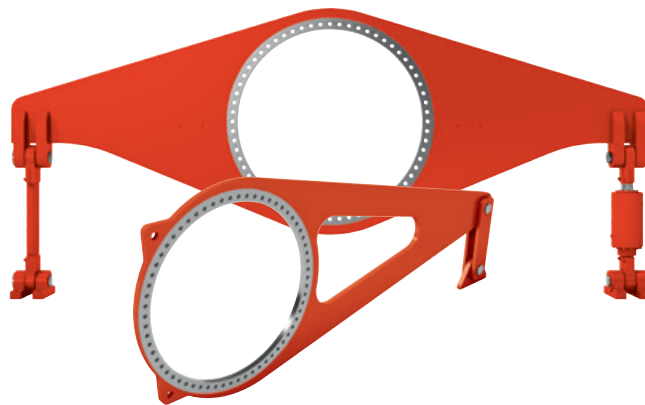

ROTATION SPEED SENSORS

Speed sensing unit, Hägglunds SPDC, is a digital incremental encoder using magnetic sensing technology. The sensor generates two square wave signals with 90° phase shift for detection of speed and direction of rotation.

- ▶ SPDC Standard
- ▶ SPDC through hole version

For more information see datasheet RE15350.

ATEX approved speed sensors are also available, see data sheets RE15351 and RE15352

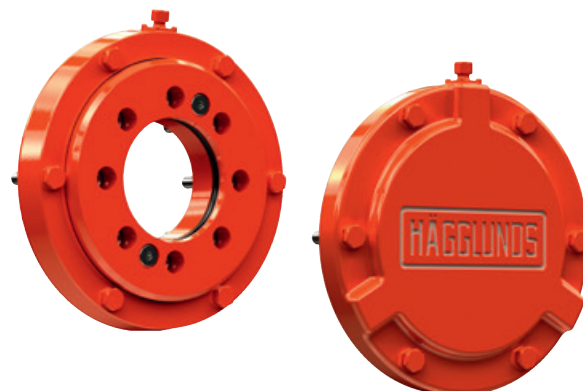

VALVES

Cross over valve Hägglunds COCB 700/1000

The cross over valve COCB is designed for use with Hägglunds CA, CB and CBM motors and provides cross line relief and cavitation protection.

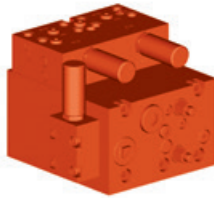

Features:

- ▶ Compact and robust design
- ▶ Mounted directly on Hägglunds motors
- ▶ Oil exchange system for closed loop (COCB 1000-3)
- ▶ Protects the motor from high pressure peaks
- ▶ Provides cavitation protection

For more information see datasheet RE15376

Free circulation valve with free-wheeling Hägglunds VFCCA 1000

The free-circulation valve with free-wheeling function is designed for use with Hägglunds CA, CB and CBm motors and provides a means of putting the motor safely into free circulation mode. The valve is also suitable for free-wheeling mode by disengaging the pistons and allowing the cylinder block to freely rotate on its bearings.

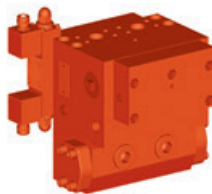

The valve is normally mounted on the motor via an adapter.

Features:

- ▶ Compact and robust design
- ▶ Mounted directly on Hägglunds motors
- ▶ Free circulation function with minimal pressure drop
- ▶ Free circulation shift allowed up to 40 rpm
- ▶ Free-wheeling function
- ▶ Shifting from drive operation into free-wheeling allowed up to 10 rpm

For more information see datasheet RE15381

Counter balance valve Hägglunds VCBCA 480

The counter balance valve is designed for use with Hägglunds Compact motors CA and CB and provides a counter balance function on one or both motor lines depending on the configuration.

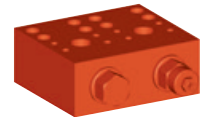

The valve can be mounted directly onto the motors

Features:

- ▶ Maximum flow 480 l/min
- ▶ Compact and robust design
- ▶ Mounted directly on Hägglunds motors
- ▶ Counter balance function with low pilot pressure
- ▶ Pilot pressure independent of load pressure

For more information see datasheet RE15378

Counter balance valve Hägglunds VCBCA 1000

The counter balance valve is designed for use with Hägglunds CA, CB and CBm motors and provides a counter balance function on the motor high pressure line.

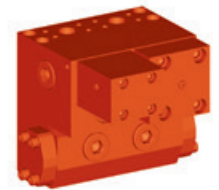

The valve is normally mounted on an adapter which is included with the valve.

Features:

- ▶ Compact and robust design
- ▶ Mounted directly on Hägglunds motors
- ▶ Counter balance function with low pilot pressure
- ▶ Pilot pressure independent of load pressure

For more information see datasheet RE15379

Four-way valve Hägglunds V4WCA 1000

The valve is designed for use with Hägglunds CA, CB and CBM motors and provides four way directional and flow control of the motor.

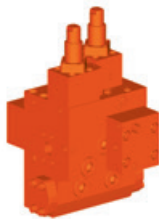

Features:

- ▶ Compact and robust design
- ▶ Mounted directly on Hägglunds motors
- ▶ Four way directional and flow control of motor
- ▶ Proportionally controlled flow of the motor
- ▶ Counter balance function on motor pressure line

For more information see datasheet RE15382

Free-wheeling valve Hägglunds VFWCB 600

All Hägglunds motors in the compact series can be operated in freewheeling mode by retracting the pistons and allowing the cylinder block to freely rotate on its bearings. The valve is designed for use with Compact motors CA, CB and CBM and provides free-wheeling of the motor by means of disconnecting the motor from the main lines and connecting both motor ports to T which has to be drained to tank



Features:

- ▶ Compact and robust design
- ▶ Multifunctional
- ▶ Mounted directly on Hägglunds motors
- ▶ Detent function on pilot valve
- ▶ Possible for remote control

For more information see datasheet RE15380

Constant tension valve Hägglunds CTCA 1000

The constant tension valve CTCA is designed for use with Hägglunds CA, CB, and CBM motors.

Features:

- ▶ Compact and robust design
- ▶ Mounted directly on Hägglunds motors
- ▶ Possible for remote control of constant tension pressure
- ▶ Multi-functional
- ▶ Constant tension function via high performance cartridge
- ▶ Dynamic braking with hot oil exchange
- ▶ Free circulation function with minimal pressure drop
- ▶ Provided with an anti-cavitation check valve

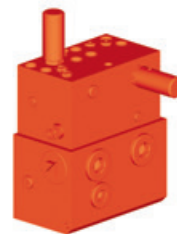
**Quick stop valve hägglunds VQCB 800**

The hydraulic quick stop valve VQCB is designed to stop a roll mill rolls without stopping the electric motor and without any need of a mechanical brake. The stop is done by blocking the oil flow from the Hägglunds hydraulic motor.

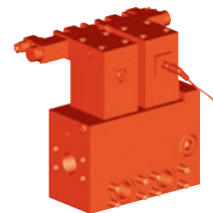

Features:

- ▶ Compact and robust design
- ▶ Mounted directly on Hägglunds motors
- ▶ Fast response time

For more information see datasheet RE15375

Valve adapters Hägglunds VA 1000

A range of valve adapters are available as accessories to the range of Hägglunds valves and motors.

Features:

- ▶ Compact and robust design
- ▶ Possibility to combine the valves and functions with each other
- ▶ Mounted directly on Hägglunds motors

For more information see datasheet RE15383

2-speed valve Hägglunds VTCA 600

The valve is designed for use with Hägglunds CA motors in 2-speed configuration and can shift displacement from full to half displacement while running up to 30 rpm and high pressure maximum 105 bar.

- ▶ Displacement shift for Hägglunds CA motor
- ▶ Compact and robust design
- ▶ Multifunctional
- ▶ Can be mounted directly on Hägglunds motors
- ▶ Built in brake control function
- ▶ Exchange of oil in motor case
- ▶ Possibility for internal control pressure.

For more information see datasheet RE15389

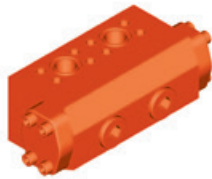
**Brake opening valve Hägglunds VBO**

The valve is designed for use with Hägglunds CA and CB motors to control the brake release pressure on MDA and BICA brakes.

The Hägglunds VBO valve is available in the configurations VBO-E that is electrically opened, and VBO-H that is hydraulically opened.

Free-wheeling and lock valve Hägglunds VFW-VHLCA

The valve is designed to be used with Hägglunds CA motors type, CA100 S.015, CA100 S.042, CA140 S.015, CA140 S.042.

Intended use of the valve is for two speed operation using free-wheeling of one part of the motor and for locking of the motor ports at a jammed drill string in a drilling application.

- ▶ Compact and robust design
- ▶ Possible for remote pilot control of check valves
- ▶ Free wheeling and lock function
- ▶ Directional valve with detent function
- ▶ Protects the motor from overspeed at drilling applications

For more information see datasheet RE15384

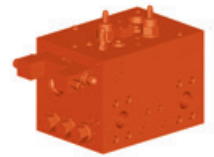

The Hägglunds direct drive system

A complete Hägglunds direct drive system from Bosch Rexroth comprises the drive unit with electric motor, pump and tank, the control system, the hydraulic motor with accessories and the piping system.

A Hägglunds hydraulic motor from Bosch Rexroth is at the center of a complete direct drive system. The full solution also comprises a drive unit with electric motor, pump and tank, as well as a piping system and control system. The complete direct drive system is a closed hydraulic loop that provides highly dynamic drive characteristics.

The hydraulic motor supplies the needed torque to the machine and the load sets the pressure level in the system. The motor rotates at the required speed, determined by the oil flow from a hydraulic swash plate pump in the drive unit. The motor is connected to the pump by means of piping and/or hoses in a closed-loop hydraulic system. The drive unit is constructed as a sound-insulated cabinet, with cooler and control system mounted on the outside for easy access.

At the hydraulic motor the oil is distributed through the valve plate to the pistons in the cylinder block, 50% of them with high pressure and 50% with charge pressure. The oil pressure forces the piston assemblies outwards radially against the cam ring. This produces a balanced and smooth rotation with extremely high torque that drives the machine. Because the speed of rotation is controlled by the flow of oil from the pump, it is possible to start the machine with full torque.

The rate and direction of the oil flow are steered by the angle of the pump swash plate, controlled via a signal from the control system. The hydraulic motor's speed is proportional to the swash plate angle. If the swash plate passes over-center, the flow is reversed and so is the direction of the hydraulic motor. Both the hydraulic motor and the pump have a very low moment of inertia, which makes it possible to change speed, stop or reverse direction quickly.

The pump is driven in turn by an electric motor, running efficiently at fixed speed. The electric motor is started in an unloaded, neutral condition to limit the load on the electrical power grid. After start, the system ramps up the flow to the required direction and flow rate.

A proportion of the return flow in the system is exchanged for oil conditioning by means of cooling and filtering. The filtration philosophy in a Hägglunds drive system is a clean tank, which means that all return and drain flow to tank is filtered. The health status in the hydraulic circuit is monitored by the control system, which sets the flow needs and is the communication link to the factory system.

DRIVE UNIT

HYDRAULIC MOTOR

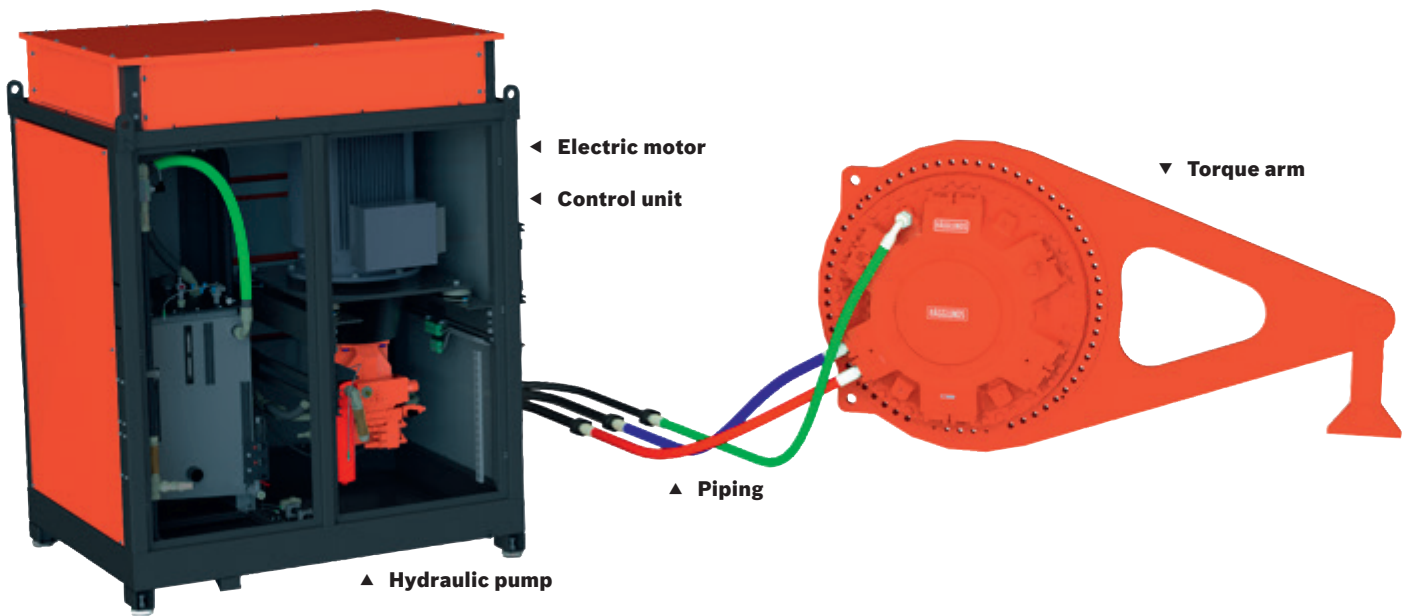

A truly flexible solution

- ▶ The hydraulic motor needs only a few additional components to form a complete direct drive system. Yet there are unlimited combinations and configurations to produce any solution within the Hägglunds direct drive performance range. Perfect load sharing characteristics enable multi-motor and/or multi-pump combinations to suit the application.
- ▶ Users can simply adjust the torque, speed and hence power provided by the motor by varying the pressure and flow. Load sensing and power limiting enable functionality unavailable from other solutions, and there are system features such as extremely fast pump compensators to provide rapid response and reduce stresses and strains on the machine.
- ▶ The enclosed motor is ideal for work in harsh environments such as dusty mining sites, ship decks, explosive zones at chemical plants and climates with wide temperature variations.
- ▶ Mounted directly on the driven shaft, the motor provides compact installation and supplies reliable power to the machine.
- ▶ The motor can be separated from the drive unit, which enables freedom of application. The drive unit can be positioned away from both motor and machine, without foundation requirements.
- ▶ The motor, like the rest of the direct drive system, is fully function-tested before delivery and requires only a short commissioning time. Installation can usually be undertaken during a normal shutdown period so that no production losses are experienced.
- ▶ Our control system, Hägglunds Spider, monitors the health of the motor and provides all the necessary start/stop logic and machine control techniques. It is mounted, wired and fully programmed on the drive unit prior to delivery.

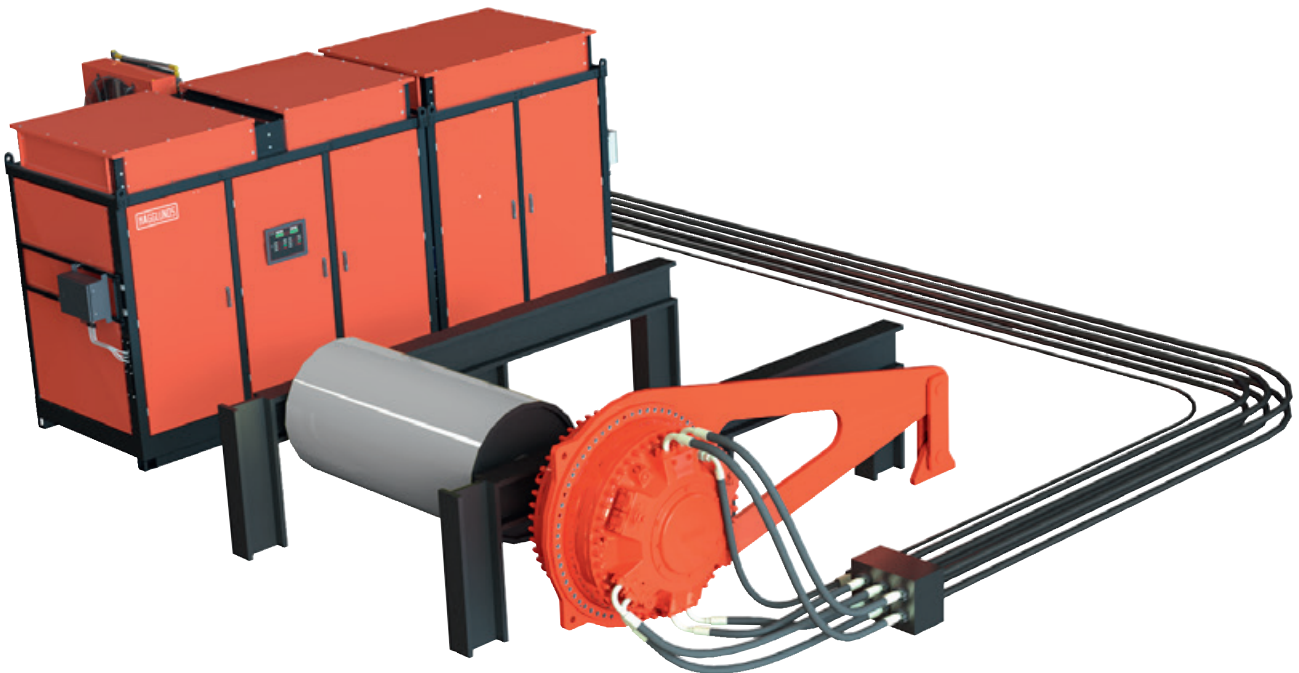

▲ Large size drive unit – one motor

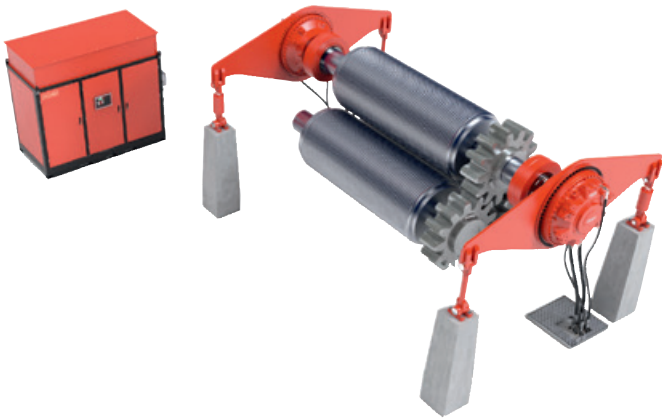

▲ Load sharing

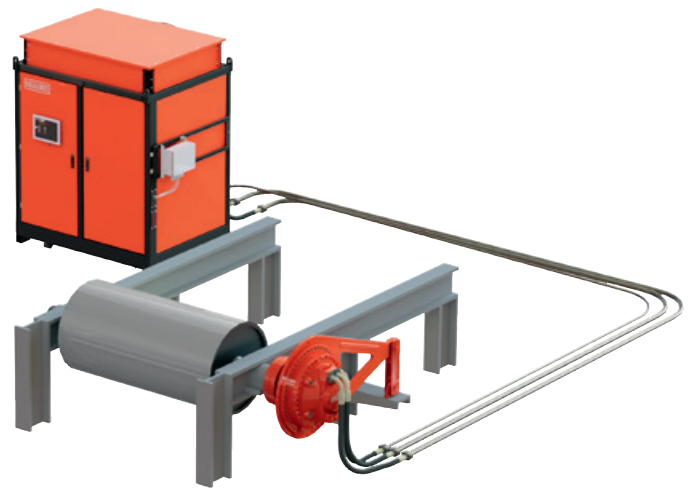

▲ Small size drive unit – one motor

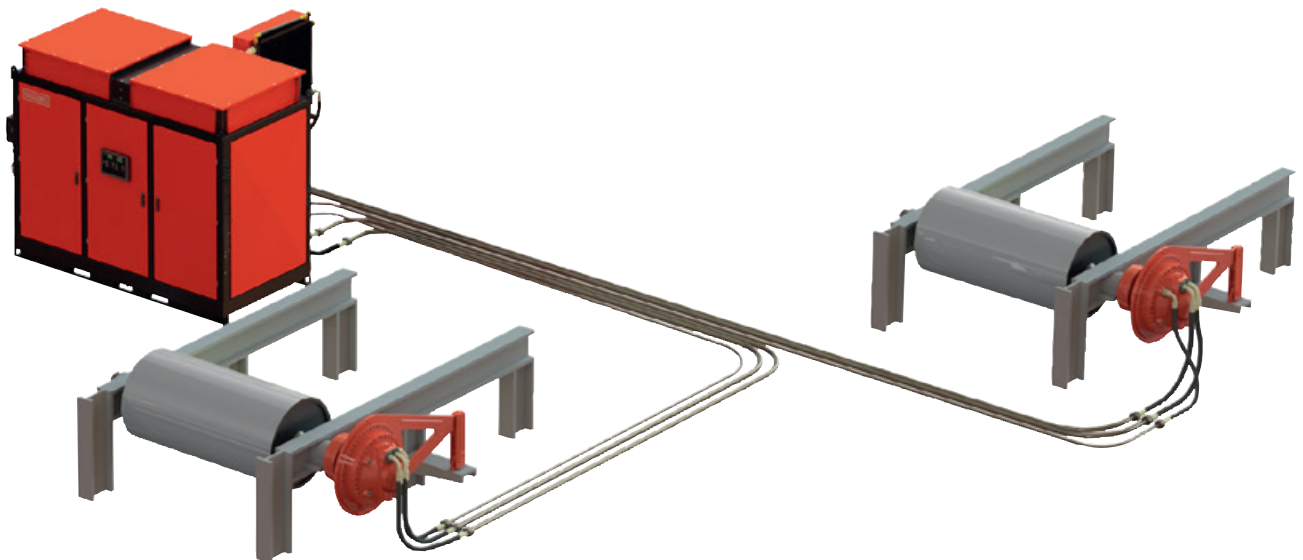

▲ Medium size drive unit – two motors

Hägglunds drive systems for explosion-risk areas

When operating technical equipment in potentially volatile areas, special precautions must be taken to protect both people and machines. Hägglunds direct drive systems from Bosch Rexroth are a versatile way to meet explosion protection requirements.

Solutions for safe productivity

Where gas, steam, solvent mist or dust pose an explosion hazard, Hägglunds direct drive systems provide vital protection – not only of equipment, but also of life and limb. Yet these rugged drives from Bosch Rexroth do more than comply with legislated standards. Their ultra-reliable component performance ensures productivity throughout the machine life cycle.

Hägglunds direct drive systems comprise a wide range of components and solutions that meet national and international directives for explosion protection. In particular, they are approved for use in explosive areas according to the ATEX Directive 2014/34/EU.

A Hägglunds direct drive system consists of a Hägglunds hydraulic motor and a Hägglunds hydraulic drive unit. Because the main components of the drive system can be separated and have individual approvals, there is high flexibility in the design and placement of the installation.

Explosion protection for your industry

Each industry has its own special requirements, both for safety and performance. Bosch Rexroth's global expertise is coordinated accordingly, so that we can offer you tailor-made solutions for your specific applications.

Explosive atmospheres involving zone 1 and zone 2 gas/air

mixtures are particular areas of focus. However, Bosch Rexroth can offer proven performance and reliable explosion protection in a much wider range of applications all over the world.

Component approvals

Hägglunds hydraulic motors of the CA, CB, CBp and CBm series are possible to use in explosive areas. The hydraulic motors are limited to gas (zone 1, category 2G and temperature class T4), dust (zone 21, category 2D and maximum surface temperature 135°C) and mining (category M2). This approval is also valid for some of the hydraulic motor accessories, including the non-electric valves and torque arms. Other motor accessories, such as brakes and speed encoders, have approvals of their own.

The Hägglunds DUE drive unit has options for usage in explosive areas, up to zone 1 and temperature class T4. Extended classification within the gas area is possible on request, as well as explosion-proof classification for geographical regions outside Europe. The drive unit's modular assembly provides high flexibility for adapting to customer function requirements, despite the limitations set by the ATEX directive.

The Hägglunds standard control system can be used if located outside the explosive zone, as long as the interface signals are handled via energy-limiting barriers.

Sample industries and applications

Häggglunds direct drive systems from Bosch Rexroth can be tailored and installed to meet ATEX requirements in industries and applications such as:

Chemical production

- ▶ Chemical reactors
- ▶ Kneader systems
- ▶ Extruder systems
- ▶ Agitators
- ▶ Gear pumps

Mining

- ▶ Feeder units
- ▶ Bucket wheel excavators
- ▶ Clamping systems for conveyor belts

Drilling

- ▶ Land-based drilling platforms
- ▶ Flushing pumps (drilling fluid)
- ▶ Lifting equipment for drilling rigs

Offshore

- ▶ Drilling platforms
- ▶ Oil refinery ships

Oil production

- ▶ Crude oil pumps



Hägglunds Original Service

Experts in drive system service, worldwide and close by

Hägglunds Original Service from Bosch Rexroth is the only true choice for service of your Hägglunds drive system. Ever since Hägglunds Drives became part of Bosch Rexroth, Rexroth has been the source for Hägglunds service, Hägglunds spare parts and Hägglunds drive system repairs. Only at Bosch Rexroth will you find the knowledge and insights that come from a half-century of servicing Hägglunds drive systems.

WHY CHOOSE HÄGGLUNDS ORIGINAL SERVICE?

High-performance drive systems need high-quality service. Bosch Rexroth is home to certified Hägglunds service specialists, whose expert training is specific to Hägglunds drive systems. Not only do they service Hägglunds motors, they take a complete drive system approach to securing your uptime.

Hägglunds service experts are supported by dedicated workshops with specialized tools and the latest technology.

Everything needed to service, repair, modernize or upgrade Hägglunds drive systems is at their fingertips, including genuine Hägglunds spare parts direct from the factory.

SERVING YOU GLOBALLY AND LOCALLY

As a truly global company, Bosch Rexroth can maximize uptime and ensure drive system performance anywhere in the world. Hägglunds Original Service is available locally wherever you are, with everything from commissioning and repairs to preventive maintenance, field service and beyond.

A FULL RANGE OF SERVICES

As the source of Hägglunds drive systems, only Bosch Rexroth can bring you the full range of Hägglunds service options, based on the latest knowledge and technology.



Häggglunds field service

From inspections to preventive maintenance, Rexroth field service engineers are ready to meet your needs on site – wherever you happen to be. Our local Häggglunds service specialists have a complete understanding of your Häggglunds drive system, as well as your situation. With their unique training and equipment, they resolve your drive issues quickly and completely.

Examples of our field service include **start-up support, condition-based maintenance, fitness checks and emergency support.**

Häggglunds drive repairs

The rugged design and leading-edge technology of Häggglunds products are the result of world-class workmanship. That same workmanship is found in the unique tools and processes used by Rexroth experts to repair Häggglunds motors and drive systems. Our skilled Häggglunds service specialists are factory-certified to repair Häggglunds products, which gives you solid assurance that the work will be done right.

Our repair offering includes **fixed-price repairs, preferred repair lead times, reman exchange, product upgrades and more.**

Häggglunds spare parts

Only genuine Häggglunds spare parts deliver the same world-class performance as the Häggglunds drive systems you depend on. Our spare parts program, which can be

combined with discounts and extended warranty options, gets Häggglunds parts to you quickly and reliably. Strategically located parts inventories, found at Rexroth service centers worldwide, ensure it.

Beyond Häggglunds parts themselves, we can offer **inventory management, dedicated spares and kits, and stocking of emergency units.**

Extended Häggglunds services

Rexroth can also provide a wide range of other services related to the Häggglunds drives and drive systems, incl:

► Remote technical support

You can turn to our Häggglunds experts for support by phone, e-mail, etc. Support time can be arranged by the hour or incorporated into a Service Agreement.

► Modernization

After a discussion of your needs, we can propose ways to upgrade your Häggglunds drive equipment and application, for example to reduce energy consumption or increase power density.

► Customer training

We can provide you with customized training packages, focused on maintaining your Häggglunds drive and getting maximum performance from your system.



Hägglunds Inside Intelligence

You and your drive system can both do more with Bosch Rexroth expertise. By selecting a Hägglunds drive solution, you've already chosen wisely. And with Hägglunds Inside Intelligence, your choice becomes that much smarter.

Hägglunds Inside Intelligence is a modern suite of products and services that connect you and your drive with Bosch Rexroth expertise. Through smart technology within your drive system – combined with mobile devices and interactive solutions – it puts our half-century of experience right in your hands.

What matters isn't the technology, but the productivity and peace of mind you achieve. Through instant analysis, real-

time advice and condition monitoring, as well as predictive maintenance and other forms of proactive support, we help you increase your drive utilization and lower your cost of ownership.

Hägglunds CM and Hägglunds CMp with ODiN, for instance, enable condition monitoring by establishing a link between your drive system and Bosch Rexroth expertise. Hägglunds CM provides entry-level monitoring and logging, while Hägglunds CMp with ODiN offers a machine health index, including historical data, trending and deeper analytics. The latter's secure and encrypted data communication lets us – or your own skilled engineers – look within your drive to optimize performance and initiate condition-based maintenance.

Using augmented reality, Hägglunds InSight Live connects Bosch Rexroth service experts with the local maintenance team on site. Through a mobile device or a pair of video goggles, our central service experts literally see what the onsite team sees. In real time, they can provide instruction and interact visually to guide service actions.

These are just a few examples from a growing portfolio of cutting-edge solutions. With Hägglunds Inside Intelligence, you have the tools to unlock the full potential of your Hägglunds drive system





Bosch Rexroth Mellansel AB

SE-895 80 Mellansel, Sweden

Phone: +46 (0)660-870 00

documentation.mll@boschrexroth.se

www.boschrexroth.com/hagglunds

Your local contact person can be found at:

www.boschrexroth.com/contact



Document No: RE15305-01

Version No: 03.2019

Replaces: -

© Bosch Rexroth AG 2019

The data specified above only serve to describe the product. No statements concerning a certain condition or suitability for a certain application can be derived from our information. The information given does not release the user from the obligation of own judgment and verification. It must be remembered that our products are subject to a natural process of wear and aging.

